

CARRON

BATHROOM & INTERIORS *Magazine*

ISSUE 4

The Design Issue

*Introducing Matt finish,
low rim and anthracite from
Carron Editions.*



News & Trends

Find out what's happening with Carron Bathrooms and the world of bathrooms and interiors.

Carron Editions:

Our new range of features and finishes are taking Carron baths to a next level.

Style Guides

A guide to bold colours and design details that bring extra style to your bathroom.

Design Focus:

We take you into the world of innovative materials and ground-breaking designers.

Carron Bathrooms

Carron Bathrooms is the UK's premier bath manufacturer. Every bath is hand finished to the exacting standards that have been our benchmark since the first Carron works opened in 1759.

GET IN TOUCH

ADDRESS:
Carron Bathrooms Limited
North Carron Works
Stenhouse Rd
Falkirk FK2 8UW
Scotland
United Kingdom

TEL: +44 (0)1324 638 407
EMAIL: info@carronbathrooms.com

FOLLOW US

FACEBOOK: facebook/carronbathrooms
TWITTER: @CarronBathrooms
YOUTUBE: www.youtube.com/CarronbathroomsUK
PINTEREST: uk.pinterest.com/carronbathrooms/

carronbathrooms.com

Credits

PHOTOGRAPHY
MARK K SEAGER,
GRAHAM WYLIE

DESIGN
SEVENFIVE
CREATIVE

ILLUSTRATIONS
EDWARD MCGOWAN

ON THE COVER

COVER
PHOTOGRAPHY
MARK K SEAGER



 carron

Contents

REGULARS

- 05** **Welcome**
A welcome to the fourth issue from Managing Director, James McMorrine.
- 06** **News + Trends**
A range of Carron updates, industry news and interior trends.
- 08** **Style Guide: Blue Hues**
Bold decor choices can bring a world of luxury and relaxation to your bathroom.
- 20** **Bathing Guide: Tasty interiors**
Bathrooms interiors don't just stop at tiles and flooring. Find out how to bring the wow factor to your bathing space.
- 22** **Range Focus: Profile**
A minimalist design approach combined with practicality has made the Profile range a customer favourite.
- 38** **Modern Life: Standing out**
If you are looking for a bath that makes a statement, Carron has a freestanding model for you.
- 46** **Range Focus: Delta Sigma**
The range that started it all for Carron. Delta/Sigma stands the test of time.
- 50** **Bathing Guide: Bathroom Sanctuary**
Our tips on how to transform your bathroom from a practical space to your own personal hideaway.



46



22

- 52** **FAQs: Cleaning**
Keep your Carron bath looking as good as possible for as long as possible.
- 54** **Style Guide: Look for the Detail**
The world of patterns and textures will bring an extra element of design and interest to your bathroom.
- 62** **FAQs: Carronite™**
What are the benefits of Carronite? Check our handy guide and find out.
- 64** **Product Range**
Our entire range in a new, easy to view format.
- 70** **Product Focus: Highland Soap**
This family owned business has a range of organic products that bring a new level of relaxation.



06



28_

12_



FEATURES

12_

Cover Feature: **Carron Editions +**

The launch of our innovative new design range will change how you think about Carron.

26_

Supplier Focus: **Baklatsidis**

Introducing our long standing partner who has been bringing the world of Carron to Greece for over 30 years.

28_

Feature: **Made in Britain**

For Carron Bathrooms, this campaign is more than just a badge, it is about everything we do.

36_

Feature: **Take a Bath**

We review the book that is showing just how far creatives are pushing the boundaries of bathroom design.

40_

Feature: **Hovia:**

This UK based company is changing the way we think about bathroom decor and design.

58_

Supplier Focus: **McAlpine**

A plumbing institution for over 100 years, we find out what make McAlpine Plumbing Products tick.



40_



Welcome

In the two years since I wrote the welcome message for the previous edition of Carron Bathrooms & Interiors Magazine, it's fair to say that our way of life has changed beyond comprehension. The pandemic presented a set of circumstances that could have come straight from the script of a Hollywood movie.

March 2020 seems like a world away now, but the effects of the lockdowns hit hard on businesses and individuals alike. Our first instinct was to protect our staff, then our business. As the dust settled, and people found a way to live with the new restrictions, attention focussed on home improvements. Demand for our baths increased, and we re-opened our factory, rising to the challenge of running a manufacturing business through a pandemic.

Emerging from lockdown, we have increasingly thought about what a company can be and how we ensure our core values are met. The key to that is partnerships. And our partnerships with suppliers (see McAlpine & Co. on p58), retailers and installers meant that despite the unprecedented challenges facing us all, we emerged with renewed energy and a commitment to adapt, grow and innovate.

We are humbled by the knowledge that installers and designers carry and that so many professionals choose to specify Carron Bathrooms. These partnerships rely on mutual trust and support and following the pandemic we have enhanced our stocks and our service offering to ensure that those professionals can work with you to complete your perfect bathroom.

It is those partnerships that led to our launch of the Carron Bathrooms Editions Range. The driving force of this "Design Edition" is a focus on products that push bath manufacturing to its limits, providing professionals with products that will make the bath tub the focal point of your bathroom while retaining all of the proven quality of Carronite™.

I am also delighted to feature Baklatsidis Bros. of Greece. A respected customer of over 30 years who, through their owner, Paris Baklatsidis, has always challenged Carron to strive for relentless improvement in design, performance and sustainability. Standards we are delighted to share with our customers globally today.

JAMES McMORRINE
MANAGING DIRECTOR

NEWS + TRENDS

The latest news, industry and bathroom trends from Carron.

DESIGN



Matt Finish Soft to the touch

2022 sees the launch of the Carron Bathrooms Editions Range and our exclusive new Matt finish acrylic baths.

Our new Matt acrylic baths, as seen in our latest model launch, the Sienna, has a soft, almost warm feel, bringing both a relaxing bathing experience and a stunning design statement in one.

This stylish bath finish has undergone three years of testing and development to make it a groundbreaker in the world of acrylic baths and a show stopper for years to come.

INTERIOR TRENDS

Trend Alert: Terrazzo

You may not be familiar with the name, but you will be familiar with the look of Terrazzo tiles. Once the go-to for hotel lobby floors and corporate buildings, this stunning yet practical and hard wearing tile design is making a comeback.

Terrazzo has been manufactured in the UK since the 1880s and became hugely popular within Art Deco interiors following the end of World War I. Like every interior style, its popularity waned. However, around 2018, designers started to incorporate this unique finish in their interiors and slowly but surely, this practical yet striking tile choice is fast becoming the go-to when creating an ultra-modern, high-end look.

Modern production methods have brought a new world of colours and finishes to the style, ensuring that Terrazzo is here to stay.

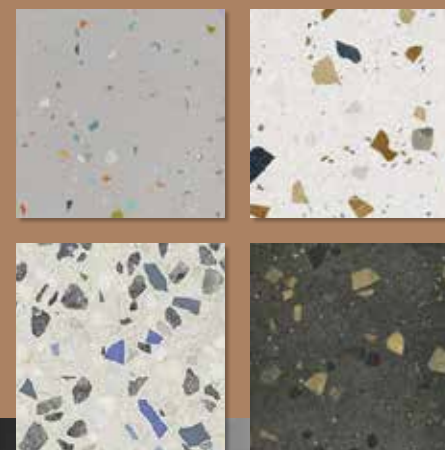

Terrazzo is the ideal tile choice if you want to add a little retro flair to your bathroom design.

BLUE HUES

Take a chance with rich coloured tiles and bring luxury and relaxation to your bathroom.



“Using brighter, richer colours on walls and floors will act as a good contrast to your bath’s clean, white finish.”





We've all looked at the design magazines with envy. Not just at the opulent interiors but also at the bold choices of colours and materials that seem just too daring when we come to decorate our bathrooms.

However, you shouldn't feel that these style options are out of your reach. Including these richer colours in your bathroom fit out will help create a

higher-end look. And you're sure to be prouder of the outcome than if you had just settled on a practical and straightforward approach.

When combined with the clean, crisp lines and bright finish of the Axis single end bath, these brighter and richer colours will always have the bath's white finish as an anchor for the design approach. This allows you to give in to your artistic side and make the bold choices you've always wanted.

Matching this luxurious colour palette with an alternative tile layout and brass or gold accessories will help you make the step towards the deluxe bathroom you deserve.

Getting the Look



Plant Pot, Brass
made.com

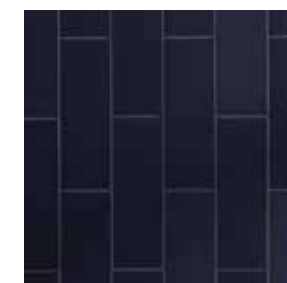

Navy Blue Subway Tiles
topstiles.co.uk



Wire Metal Chair, Gold
cultfurniture.com



White Bark Cork Tiles
wallsandfloors.co.uk



Round Mirror, Brass
Made.com



Wall mounted sink, driftwood
q4bathrooms.com

Golden touch

Deep blue walls, be they finished in tiles or paint, go well with chrome, brass and even gold fittings and accessories.

Carron
Editions⁺

The Editions Collection



With subtle design statements, stylish finishes, and even an exclusive new bath model, the innovative Carron Editions range from Carron Bathrooms takes our baths and accessories to the next level.

Carron Baths have always been designed to look good in the home and come with a range of practical benefits. We've built our name on attention to detail, service, and reliability. That doesn't mean we can't give you more.

Sometimes we want to innovate while also addressing the latest trends. We want you to have a bath that comes with all the Carron reliability, but we also want to help you create a bathroom with a wow factor.

The Carron Editions range covers innovative new bath finishes, design details for new models and existing Carron favourites, and a range of accessories that will impact any bathroom.

The Editions range will change how you think about Carron Bathrooms.

+ Matt Finish

Smooth, warm and incredibly tactile. The Carron Editions Matt Finish option is a game-changer for the world of bathing and bathroom design. The reliable and practical benefits of acrylic are teamed with a sumptuous finish that has only been available with ceramics and pottery.

Matt finish baths bring a whole new world of bathroom options and décor choices. High end sinks, and cutting-edge brassware will team perfectly with this design statement.

Carron Editions make a modern design statement while taking acrylic baths to the next level



+ Low Rim

Our Low Rim feature adds a layer of sophisticated detailing ideal for inset baths. Minimalism and subtlety lead the way here, as the simple yet effective reduction in bath lip height creates a streamlined effect, bringing the bath lower to the plinth or base. This way, the tub can better merge with the surrounding décor without losing any of its impact.

The new Low Rim height takes a standard rectangular bath to the next level. Inset into a plinth, the bath becomes a sleek design feature.



+ Anthracite Accessories

We created the Carron Bathrooms range of Anthracite Accessories to make an impact. The stylish, matt black finish is available for a range of Carron baths, so whether you have a freestanding statement model or a practical showerbath, the simple addition of Anthracite can change the whole look and feel of your bathroom.

The Anthracite finish is available across all Carron waste, overflow and filler accessories and is available for the inset grips on all Quantum Integra models.

“ Carron Editions range covers innovative new bath finishes, design details for new models and existing Carron favourites ”



Choosing your new Carron bath is fun but a bathroom fit out doesn't stop at baths, plumbing and tiles. There are a number of tips and tricks to bring 'extra style' to your bathroom and here are our top five.

01

Be bold

Bathrooms are commonly known as the smallest room in the house. And for a good reason. But small spaces don't mean you can't go bold with your decor and fittings. Choosing bright or bold colours helps your crisp white bath and sink stand out. While being eclectic with your fixtures and fittings also makes a big statement. Mixing a traditional bath like the Carron Ascoli with modern, minimalist copper fittings will add a distinctive finishing touch.



02

Paper and paste

It doesn't need to be paint or tiles for the bathroom walls. Bold wallpapers are on-trend, and they can allow you to go for something truly stunning that might be a bit too much in another room. Single, bold designs, such as tropical foliage or flamingos, make a change from plain patterns and will make a big impression.

03

Beauty show

For every pretty, well-designed toiletry product you own, there are a load of ugly, half empty, messy bottles of shampoo and shower gel lying around. Where possible, give room to your attractive beauty products and get them on display while finding somewhere practical and enclosed to hide away products that may be useful but are less pleasing to the eye.



04

Top tiles

Opting for high-end tiles but using less of them can be a cost-effective way to add some wow factor to your bathroom. Small feature areas for tiles help keep the cost down while adding real impact where it matters most. This is where statement tiles such as Terrazzo come into play. Or deep blue subway tiles – always a favourite for the Carron team.

05

Accessorise

With all the big jobs completed, don't forget about the accessories as those finishing details can make all the difference. Using Carron's new anthracite accessories can bring a modern industrial feel to your design with little effort or expense. The range covers wastes, fillers and handgrips for the Quantum Integra, and the dark, matt finish adds an extra level of style.

Illustrations by
Edward McGowan

TOP 5
TIPS
FOR

Tasty Interiors



Bathroom design walks a fine line between functionality and fashion. So when Carron Bathrooms designed the Profile range, we knew the baths had to make an impact while still being practical.

T

The world is becoming more used to a minimalist design approach, with everything from cars to mobile phones becoming sleeker and more refined. For Carron, the shift in direction by ceramic sanitary ware manufacturers allowed our design team to follow their trends when developing this new range.

As the simple, rimless design effect was beginning to emerge in the design of WC's and basins, Carron had to look for a way to incorporate this look while also ensuring the baths could accommodate essentials like a shower screen. For the Profile range to succeed, it had to be as close to the rimless effect as possible.

The minimalist design approach and near rimless effect also had another benefit. The tighter rims also managed to maximise bathing space. We were creating a sleek bath with increased comfort and room to bathe.

RANGE FOCUS:

Profile

RANGE

Design Features:

PRACTICAL
SLIM LINE

Available:

3 MODELS
9 SIZES

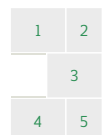

Featured Baths:

[1] & [2] **PROFILE SHOWERBATH**

[3] **PROFILE SE**

[4] & [5] **PROFILE DUO**



The Profile's success has been beyond even the most optimistic expectations of Carron. As Marketing Manager Lynn Jarvie explains, "In 2015, we took the Profile to the market. When approaching our customers, we believed the bath was so distinctive that showrooms would embrace it. We underestimated how popular it would be. Almost every showroom we visited wanted one on display, and the customer interest grew from there."

The Profile range has grown to include nine sizes, including a double-ended version and a Showerbath. Both were created due to customer demand. There is also a compact 1600x700 size - ideal for smaller bathrooms.

The Profile has gone from strength to strength since its launch, and its popularity shows no signs of slowing down yet.

For full specification and more information on the Profile Range, visit www.carronbathrooms.com

Following trends is all well and good, but at Carron Bathrooms, we need our baths to be functional, reliable, and stylish.

The Profile Range



Profile

FEATURES: **C** Carronite, **P** Panel

LENGTH X WIDTH	HEIGHT	DEPTH	CAPACITY
1500 x 700mm	515mm	400mm	190 Litres
1600 x 700mm	515mm	400mm	204 Litres
1700 x 700mm	515mm	400mm	218 Litres
1700 x 750mm	540mm	430mm	257 Litres
1750 x 750mm	540mm	410mm	264 Litres
1800 x 700mm	540mm	400mm	255 Litres



Profile Duo

FEATURES: **C** Carronite, **P** Panel

LENGTH X WIDTH	HEIGHT	DEPTH	CAPACITY
1600 x 700mm	515mm	410mm	188 Litres
1600 x 800mm	540mm	410mm	215 Litres
1650 x 700mm	515mm	410mm	200 Litres
1700 x 700mm	515mm	410mm	205 Litres
1700 x 750mm	540mm	410mm	230 Litres
1750 x 750mm	540mm	410mm	236 Litres
1800 x 700mm	540mm	410mm	231 Litres



Profile Showerbath

FEATURES: **C** Carronite, **P** Panel

LENGTH X WIDTH	HEIGHT	DEPTH	CAPACITY
1500 x 900mm	540mm	440mm	241 Litres

Available in right hand or left hand. Left hand shown. Not suitable to be recessed.



Paris Baklatsidis,
Managing Director
www.baklatsidis.gr



From Falkirk to Thessaloniki

Carron Bathrooms are Britain's leading bath manufacturer, but our products reach much further afield than this. Here we speak to Paris Baklatsidis, Managing Director of Baklatsidis Bros. in Themi - Thessaloniki, Greece.



Q. Baklatsidis Bros. is one of Greece's leading bathroom wholesale companies. When was the business founded?

A. The business was initially founded in the 1960s, over 50 years ago. Over the decades, Baklatsidis has become the most extensive bathroom and kitchen product wholesale company in Greece.

Q. Your facilities have grown dramatically over the years.

A. Our Head Offices, Warehouse and Showroom are located in the area of Themi - Thessaloniki. These facilities span some 15.500 sqm and are the starting point for all our daily shipments throughout Greece.

In 2005, we opened our 2000 sqm Athens showroom to help us better serve the city of Athens and Southern Greece.

Q. In what areas of the bathroom industry do you specialise?

A. The entire supply, installation and aftercare service for all manner of bathroom installation. We have the product and skills necessary for our clients, from single, domestic projects to extensive hotel complexes.

Q. What do you think makes Baklatsidis Bros. stand out from your competitors?

A. We have complete confidence in being able to deliver for our clients. We do this by ensuring a massive stock range is available for dispatch at all times.

We back this up with the combined benefits of our extensive experience and excellent after-sales service.

Q. You have a reputation for working on large commercial projects. What kind of services do you supply for this type of client?

A. At Baklatsidis Bros, we pride ourselves on providing our clients with an end-to-end service. Through this approach, we have had the opportunity to work with some of the largest hotel complexes in Greece, such as Macedonia Airport, Macedonia Palace, and Porto Carras.

The success of these projects has led us to become one of the principal suppliers of Greek hoteliers.

Our abundant stock availability and our experienced sales force help ensure that from the moment we start working with our clients, they are in safe hands and can feel fully confident we can deliver on our promises.

Q. Are there any projects or clients are you most proud of?

A. Throughout these successful years in the bathroom equipment business, we had a lot of clients with whom we are proud to be partners. They belong to the top list of famous architectural offices, leading constructor companies, high-end bathroom retailers etc.

Over the decades, we have had the opportunity to work with a wide range of famous architectural offices, leading constructor companies and high-end bathroom retailers.

However, there is a certain kudos to working with a well know, international brand. And it is through our work in the hotel industry, we have had the chance to work with names such as Intercontinental, Hilton, Holiday Inn, and the Hyatt Regency Casino.

Q. How long have you worked with Carron Bathrooms?

A. We have been working with Carron Bathrooms since the early '90s, and I'm happy to say we're still working together 30 years later!

Q. Why would you recommend Carron products?

A. They adhere to strict product specifications while still striving to innovate. Simply put, it is the quality of their products. Customers can find this quality in products like their unique, Carronite material and the constant pursuit of market trends that have helped place Carron Bathrooms among the top bathtub manufacturers globally.

Q. Finally, you have overseen countless bathroom installations over the years; what tips would you give people when choosing a new bath?

A. Choose quality products from manufacturers with high standards. This way, you know day-to-day usage of your bathroom will be easy and enjoyable. Ergonomic design, functionality, aesthetics, cleaning and maintenance, safety, and now more than ever, eco-credentials are all essential elements.

If you take all these elements into account and buy the best products you can afford, you'll be enjoying your bathroom for years to come.

We are proud to be part of the Made in Britain campaign, but for Carron Bathrooms, it means more than that.

MADE IN BRITAIN



M

Made in Britain brings together the British manufacturing community, united with the use of the registered collective mark and a guarantee that the member is a British manufacturer.

We are proud to be a member as we are passionate about British manufacturing. This pride is just part of why we use the Made in Britain marque and why we are so proud that all our baths are manufactured and finished by hand at our factory in Falkirk, Scotland.

The main goal of Carron Bathrooms, above all else, is to create first-class products.

We make our baths for the consumer. These people will use our products day in, day out for years. However, we are constantly striving to be the professional's choice. This goal means creating baths that don't just look good but perform well, too.

Conformance needs to be of the highest level. Every bath needs to be produced and finished accurately and to the correct specification for each model. This way, we know that the trade, installers and retailers alike will have a product that is easily installed, reliable in use and will result in a happy customer without any complaints.

We also need to recognise our responsibility to our environment by making robust products with remarkable heat retaining properties. Local manufacturing means reduced shipping miles too.



“

The main goal of Carron Bathrooms, above all else, is to create first-class products.

”





We believe our commitment to our customers doesn't end when the bath is purchased, so we also offer 20 and 30-year guarantees for our baths.

This commitment to excellence doesn't just mean ticking boxes for the trade. It also means we need to be relentless in pursuing improvements such as the substantial, continuous investment into our manufacturing processes. This is best seen in our new HE3 automated production line, being commissioned mid-2022, and designed to increase efficiency and conformance while still ensuring skilled manufacturing jobs for our workforce.

Our commitment to doing better stretches outside of the factory and the world of manufacturing. We proactively engage with our local community to be a force for good. We are investing in local environmental and green space projects and supporting local community and charity groups.

This commitment is part of our goal to be a good corporate citizen who treats our customers, suppliers, employees, and community with respect.

Ultimately, being part of Made in Britain ensures one thing. The revenue generated at Carron is distributed to our (exclusive) UK based workforce and back to the UK economy.

These reasons combined mean Carron Bathrooms will continue to be a proud ambassador of UK manufacturing excellence overseas. And proud to be Made in Britain.

...being part of Made in Britain ensures one thing. The revenue generated at Carron is distributed to our (exclusive) UK based workforce and back to the UK economy.

Take A Bath, Interior Design
For Bathrooms, £40.00

Available online at:
gestalten.com



Whether looking for resourceful solutions for a guest bathroom or rich details to add to a decadent master bath, you are sure to find inspiration within the pages of Take a Bath.

TAKE A Bath

Although the bathroom has historically been seen as a functional room, a growing number of architects and interior designers are seeing the space as an opportunity to flex their creative muscles. **Take a Bath**, published by Gestalten, looks at these creatives and how they shake up conventional thinking when it comes to bathroom design.

The book is the perfect showcase for how designers harness creativity and take a fresh look at the bathroom.

Taking in conceptual finishes from the contemporary to the classic as seen in the Terrazzo tiles designed by Max Lamb for Dzek (bottom right). The concept of tiles is pushed beyond the simple white square to encompass a range of textures, finishes and colours. Split into four sections focusing on different materials, the book looks at how they can be used in contemporary interiors.

Natural materials are seen as more than just décor as the architectural merges with the interior. Framing, struts and beams become as much a part of the bathroom as the fixtures and fittings. Aged wood, copper and stone are used to bring heritage and patina to contrast with the crisp white finish of the baths.

There is also the world of the modern and conceptual interior to balance the more familiar finishes. Minimal approaches are seen from Piero Lissoni where resin, mirror and smooth rendered surfaces collide. And an intriguing and considerably more accessible look at the use of coloured pottery and baths along with new ways to use wood veneer and even wallpaper (main image).



A growing number of architects and interior designers are seeing the bathroom as an opportunity to flex their creative muscles



Take a Bath treads the line between the conceptual and the practical and introduces us to a community of designers seeing just how far they can push the bathroom concept. Whether you prefer to be traditional or modern, there is plenty of inspiration here for even the most modest bathrooms spaces.

Nowhere is this better summed up than by designer Roberto Palombo. "the bathroom of the future will increasingly evolve from a functional area into a living space.. a room full of colour, innovative materials and forms..."

Take a Bath is available to buy now from gestalten.com

All imagery © Gestalten 2017



Not every bathroom is designed just for function. Some people want their space to celebrate design and interior style. For this you need a bath that can make a statement.



O

Halcyon D

This statement bath is designed to be a bit of a hybrid. Combining the impressive look and feel of a freestanding bath with the practicality of a wall-mounted model. If you crave that big tub feel but maybe lack the space, the Halcyon D is perfect.



U

Paradigm

The best way to describe the Paradigm would be curvy and quirky. Its unique oval shape has a deceptively small footprint while also providing a comfortable, wrap-around bathing space.

At Carron, we have a range of freestanding baths that will work for a variety of bathrooms sizes and styles. From quirky to traditional and functional to luxurious, we have a tub that will really stand out.

Celsius Freestanding

This Carron flagship model is a large and luxurious tub that makes the ultimate statement. Finished in Carronite 'as' standard, the Celsius comes complete with a custom-fitted base, filler and waste.



Ascoli

When you think of a freestanding bath, you picture a bath like the Carron Ascoli. This bath certainly stands out with its traditional roll-top and antique-style feet. And if you want to take things to the next level, we can finish the exterior in the colour of your choice with our ColourMatch service.

T



STANDING



A WORK OF ART

When you think about decorating your bathroom, your first choice may not be wallpaper. However, with some innovative new production techniques and finishes now available, this stunning approach to wall design could be the next big thing for bathrooms.

Bathrooms are traditionally tricky places to paper. The humidity creates problems with hanging the wallpaper, and you live in fear of it getting wet and starting to peel.

You can now put these worries behind you as companies like Hovia and Wall & Deco have developed innovative new products that bring the beauty of stunning, contemporary patterns, imagery and art to your bathroom.

Hovia, based in Liverpool, is a custom surface design company with innovation at its heart, passionate about bringing beautiful digital design to walls and floors. Its wallpapers range from simple patterns to statement prints explicitly produced to the dimensions of your room. Helping you turn your bathroom wall into a work of art.

At Carron Bathrooms, we're big fans of Hovia and have used their products for photo shoot roomsets over the years. This is best seen in the stunning botanical print teamed with our custom ColourMatch Ascoli bath. Helping the green of the bath exterior pop against the vintage styling of the wallpaper.



“

The bathroom is a strong enough space to handle rich and luxurious imagery, creating the perfect backdrop for a statement bath

”





The bathroom is a strong enough space to handle rich and luxurious imagery, creating the perfect backdrop for a statement bath and all installed in a fraction of the time it takes to tile a wall.

Or how about adding the work of an old master to your interior design? With a range of classic art from Van Gogh, Vermeer and Matisse, you can transform the smallest room in the house into an art gallery.

These wallpapers are hung the same way as standard papers, but the possibilities are almost endless with the added option of having the paper custom printed to fit your wall.

Their drive to innovate doesn't just stop at the paper. Hovia has achieved a carbon-neutral status and is committed to offsetting more carbon emissions from 2022. With a green outlook to match its artistic eye, Hovia could be a company worth checking out.

For more information, go to hovia.com



innovative new products that bring the beauty of stunning, contemporary patterns, imagery and art to your bathroom



RANGE FOCUS:

Delta & Sigma

RANGE

Design Features:

SMOOTH DETAILS
FLEXIBLE DESIGN

Available:

4 MODELS
14 SIZES

Every industry needs to innovate and move forward, but some products stand the test of time. If a range looks good and functions well, it will go from strength to strength. Enter the Delta/Sigma range.

B

Bathtubs in busy homes need to be a bit of a workhorse, from the bathing of small children to the multiple showers required daily by busy teens and adults. And don't forget the relaxing soak at the end of that day as you try to grab those few moments of peace and serenity. For all this, you need a thoughtful and flexible bath design.

The Delta/Sigma range started small, as do many of our ranges. But its flexibility and practicality soon brought demand for more and more bath types and sizes. The more compact Deltas have six size variations on the single end model alone. There are also two showerbath sizes options that help provide dual functionality so often needed in busy family homes.

For the Sigma, the slightly more generous dimensions run to five size variations as well as an impressive 1800 x 750-900mm showerbath that help take this tub from workhorse to powerhouse.

However, practicality isn't the only requirement for a do-it-all bath. Comfort is also a major factor when choosing a bath.

This timeless range features a wide tap ledge to provide flexibility for tap styles and positions. However, the flawless, curved slope at the head of the bath is the Delta/Sigma's most distinctive design detail. The smooth transition to the bath base creates an ideal bathing position. Perfect for soothing tired muscles while escaping from the stresses and strains of the day.

Different baths provide solutions for various needs and requirements. If you need a tub that is many things to many people, then the Delta/Sigma range could be the tub of your dreams.

For full specification and more information on the Delta & Sigma Range, visit www.carronbathrooms.com

The elegant Delta Sigma family are the designs that started it all for Carron, a bath designed without compromise.

The Delta & Sigma Range



Delta

FEATURES:

LENGTH X WIDTH	HEIGHT	DEPTH	CAPACITY
1400 x 700mm	515mm	410mm	142 Litres
1500 x 700mm	515mm	410mm	152 Litres
1600 x 700mm	515mm	410mm	162 Litres
1650 x 700mm	515mm	410mm	167 Litres
1675 x 700mm	515mm	410mm	170 Litres
1700 x 700mm	515mm	410mm	170 Litres



Sigma

LENGTH X WIDTH	HEIGHT	DEPTH	CAPACITY
1600 x 750mm	540mm	420mm	175 Litres
1700 x 750mm	540mm	440mm	195 Litres
1700 x 800mm	540mm	450mm	220 Litres
1800 x 800mm	540mm	450mm	240 Litres
1900 x 900mm	570mm	460mm	350 Litres

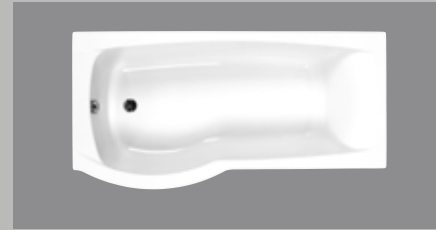

Delta Showerbath

LENGTH X WIDTH	HEIGHT	DEPTH	CAPACITY
1600 x 700-800mm	540mm	410mm	210 Litres
1700 x 700-800mm	540mm	420mm	230 Litres

Available in right hand or left hand. Left hand shown.



Sigma Showerbath

LENGTH X WIDTH	HEIGHT	DEPTH	CAPACITY
1800 x 750-900mm	540mm	450mm	265 Litres

Available in right hand or left hand. Left hand shown.

Grip Options

Chrome Handgrip, CCG-1 Available on Delta and Sigma rectangular baths.

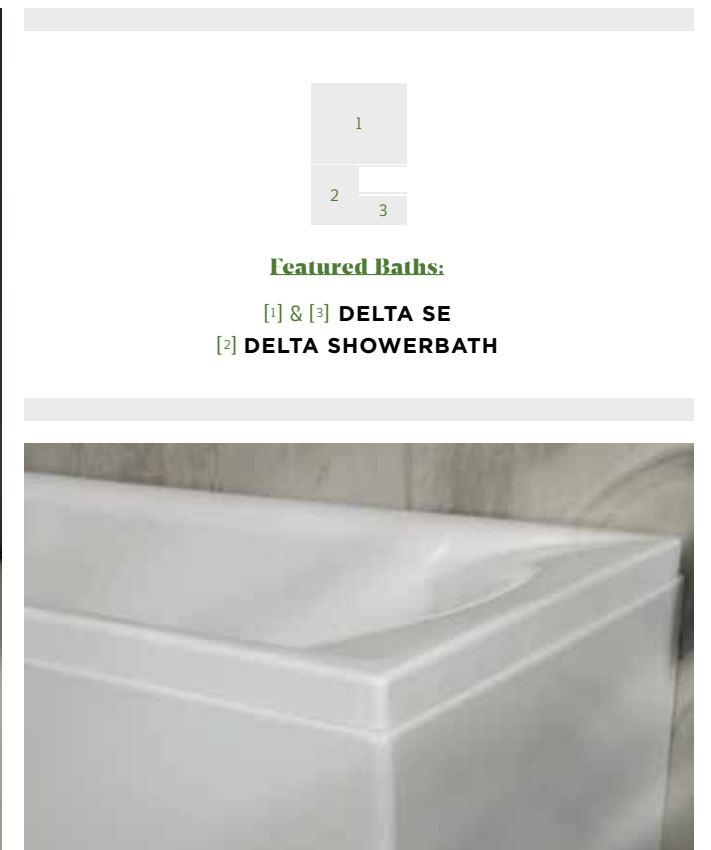

Featured Baths:

- [1] & [3] DELTA SE
- [2] DELTA SHOWERBATH

**TOP 5
TIPS** FOR

Bathroom Sanctuary

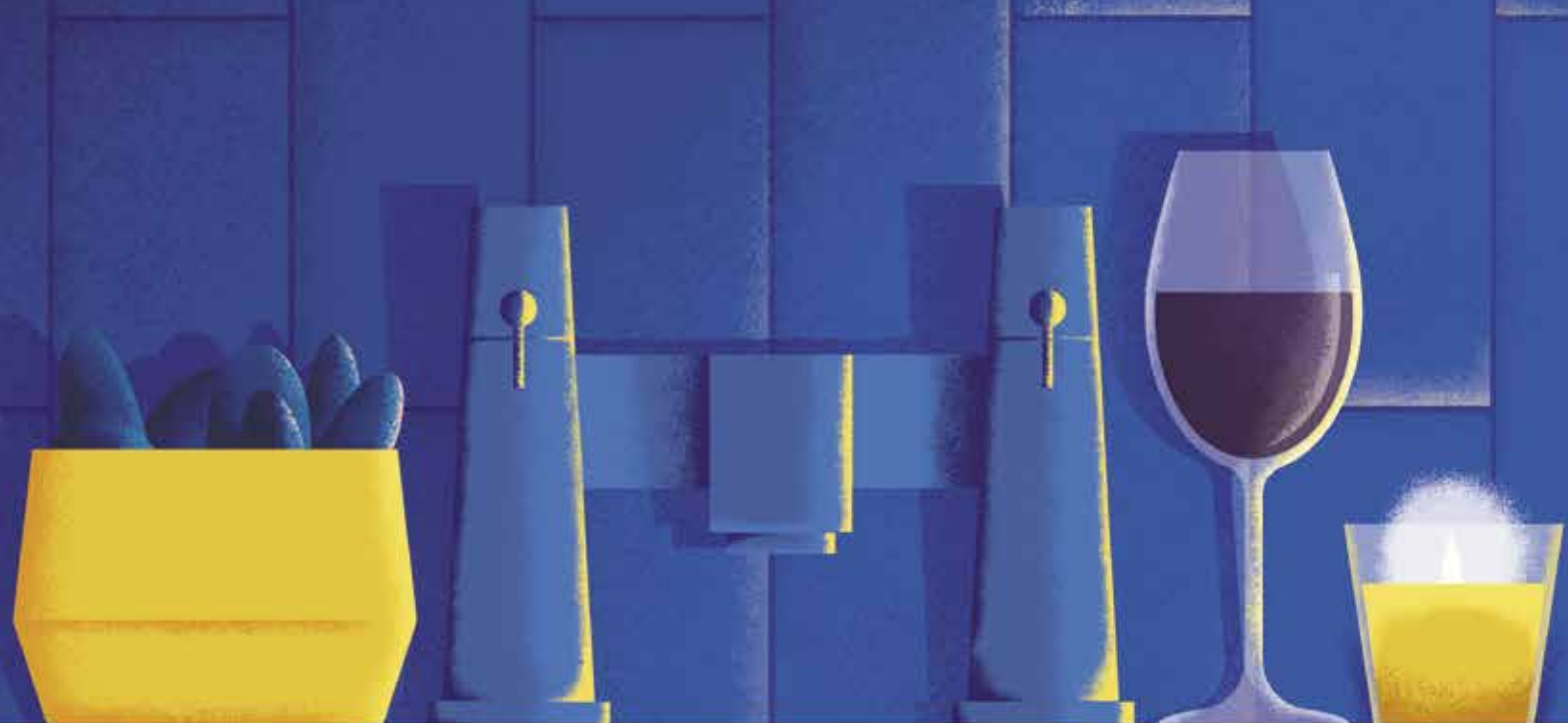

Illustrations by
Edward McGowan



Deep dark and sumptuous. The bathroom as a sanctuary to hide away from the world and relax.

01

Pamper

The first step to creating that special space is making sure you're taking care of yourself. Warm and fluffy towels will help extend the feeling of relaxation from your bath, and upgrading your candle selection goes a long way to creating that sanctuary feel as well. Aromatherapy candles have a range of benefits, so try adding a bit of lavender for relaxation or green fig to help you de-stress.

02

De-Clutter

The simplest and cheapest step to turning your bathroom from a functional and slightly messy space into that inviting and relaxing sanctuary your body needs. To ensure you give yourself the best opportunity to relax and unwind, clear out the clutter. Dispose of unused or unusable bottles and containers, clean up, and you'll be one step closer to bathing nirvana.

03

Lighten the mood

Your choice of lighting will go a long way to help create the atmosphere you crave. Don't be afraid to go for light fixtures that you might find elsewhere in the home. Wall sconces will help avoid the glare you get from bright ceiling lights while using lower wattage; warm light bulbs help add to the effect.

04

Delicate Decor

Glaring white tiles might have a practical appeal. However, if you want to create a warm and inviting space away from the hustle and bustle of your busy home, rich, sumptuous colours are the way to go. Deep blues and warm reds absorb the light and go a long way to create a relaxation bubble.

05

Bring on the bubbles

What better way to relax in your newly improved bathroom sanctuary than treating yourself to a Whirlpool bath? Carron has a range of C-Lenda Whirlpool systems that bring that extra level of relaxation to the bathroom. You can choose from a range of jet profiles to help massage those tired muscles or upgrade to include a relaxing LED light system that will help soothe the mind, too.



FAQs

CLEANING YOUR BATH

One of the most common requests we receive from customers is the best way to take care of their new bath. Cleaning a bath may seem straightforward but if you follow our simple cleaning guide, you can guarantee your Carron bath will look as good as the day it was installed.



BATH FAQs

1

Cleaning should be done immediately after use, whilst the bath is still warm. This way, the layer of insoluble soap, grease and dirt which would otherwise harden on the surface can be removed more easily.

2



We recommend simply using a small amount of mild detergent, or a bathroom cleaner such as CIF Cream Cleaner.

3



Avoid leaving lit cigarettes or any other heat source on or near the surface of the bath.

4



After cleaning, rinse thoroughly with clean water.

5

Do not bring into contact with sharp edges. Pointed objects could scratch the bath surface.

6

Each time after use, clean the bath thoroughly with warm soapy water.

7

In areas with particularly hard water, insoluble calcium salts may form deposits on the taps and along the water line. In order to avoid these, clean the bath with a soft sponge and detergent in hot water immediately after use. Rinse with plenty of cold water.

8



Warning: abrasive powder cleaners may scratch the surface of your bath.



LOOK FOR THE DETAIL

Adding patterns and textures to your décor can bring a new level of design detail to your bathroom.

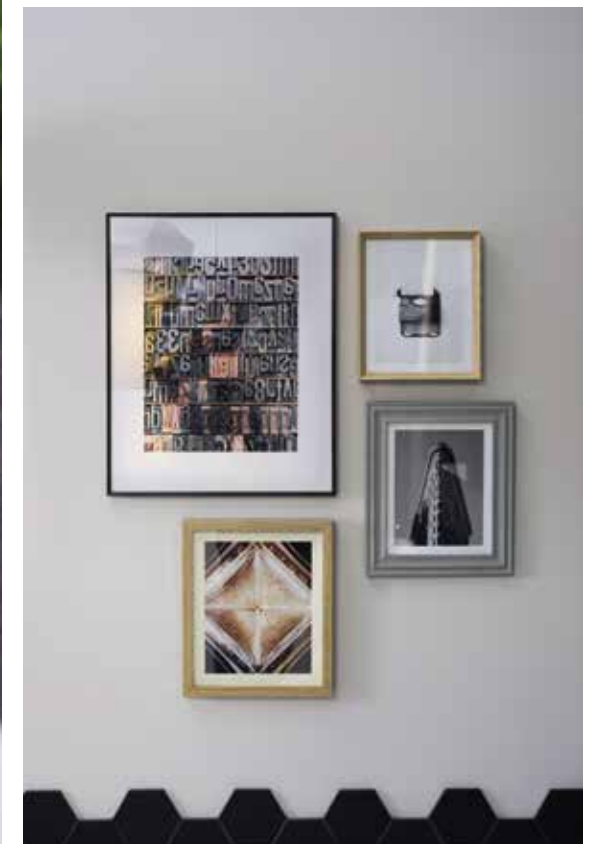

“
Intricate shapes and exciting patterns can be found in the form of tile layouts, floor finishes and towels and textiles.
”

Getting the Look



The Carron Bathrooms Quantum Integra is an excellent bath for various bathroom styles. It has a cool, unfussy design and fits well with sinks and sanitary ware that follow a similar, stylish approach. So, if the main features in your bathroom are understated, what is the easiest way to add interest? For this problem, you need patterns and textures.

The smooth, flawless finish of your Carron bath will act as the perfect backdrop to more detailed finishes and accessories.

Tiles with more intricate shapes can create exciting patterns, and simple subway tiles fitted in a herringbone style will add interest. Team these wall finishes with tactile materials such as wicker laundry baskets, wooden vanity units, and shelves to add more natural elements.

However, the details don't have to stop there. Thick, fluffy towels, duckboards, and house plants bring interest and individuality to the bathroom.

Your bathroom may need to be the most practical room, but it doesn't have to be the least interesting!



Cotton Storage Basket, Dark Grey
hm.com



Bath Towel Set, Warm Grey
Made.com



Round Stool, Black
wayfair.com



Wood Herringbone Laminate Flooring
diy.com



Black Matt Hexagon Tiles
wallsandfloors.co.uk



Cluster Pendant Light, Grey
Made.com

Shades of Grey

Avoid patterns and textures clashing by following a reduced colour palette. Warm or cool greys are an excellent choice for bathrooms.

**SUPPLIER
FOCUS:**

McALPINE

A plumbing institution

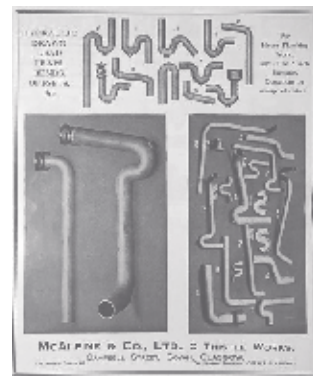
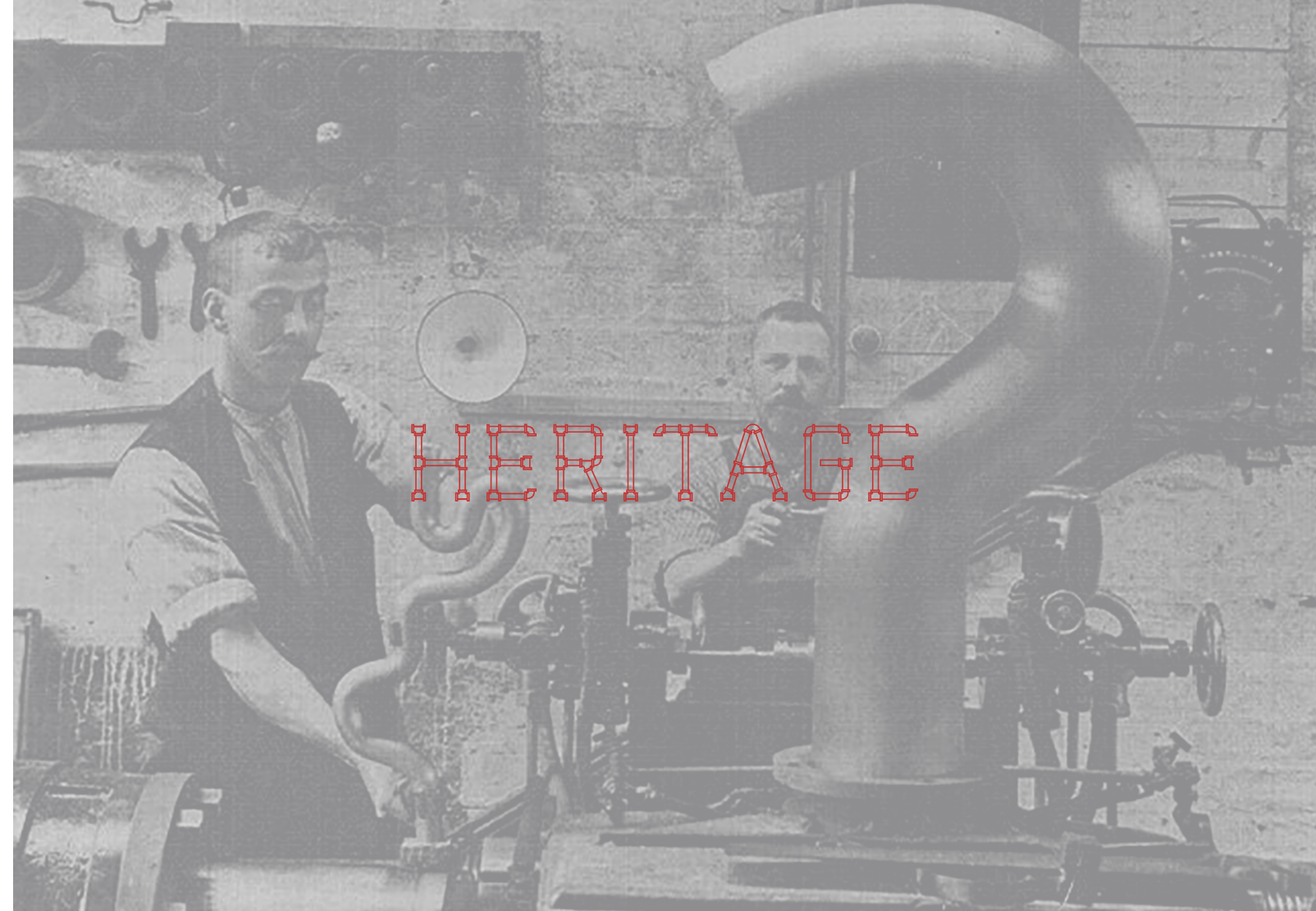

The name McAlpine is synonymous with plumbing supplies and has been since the early 1900s. Here we speak to the company's Managing Director, Robert McAlpine, to find out more about the company history and get an insight into their plans for the future.

Background Info:
McAlpine is a Glasgow based plumbing manufacturer that employs nearly 800 people. Many of whom have generations of family working within our company.

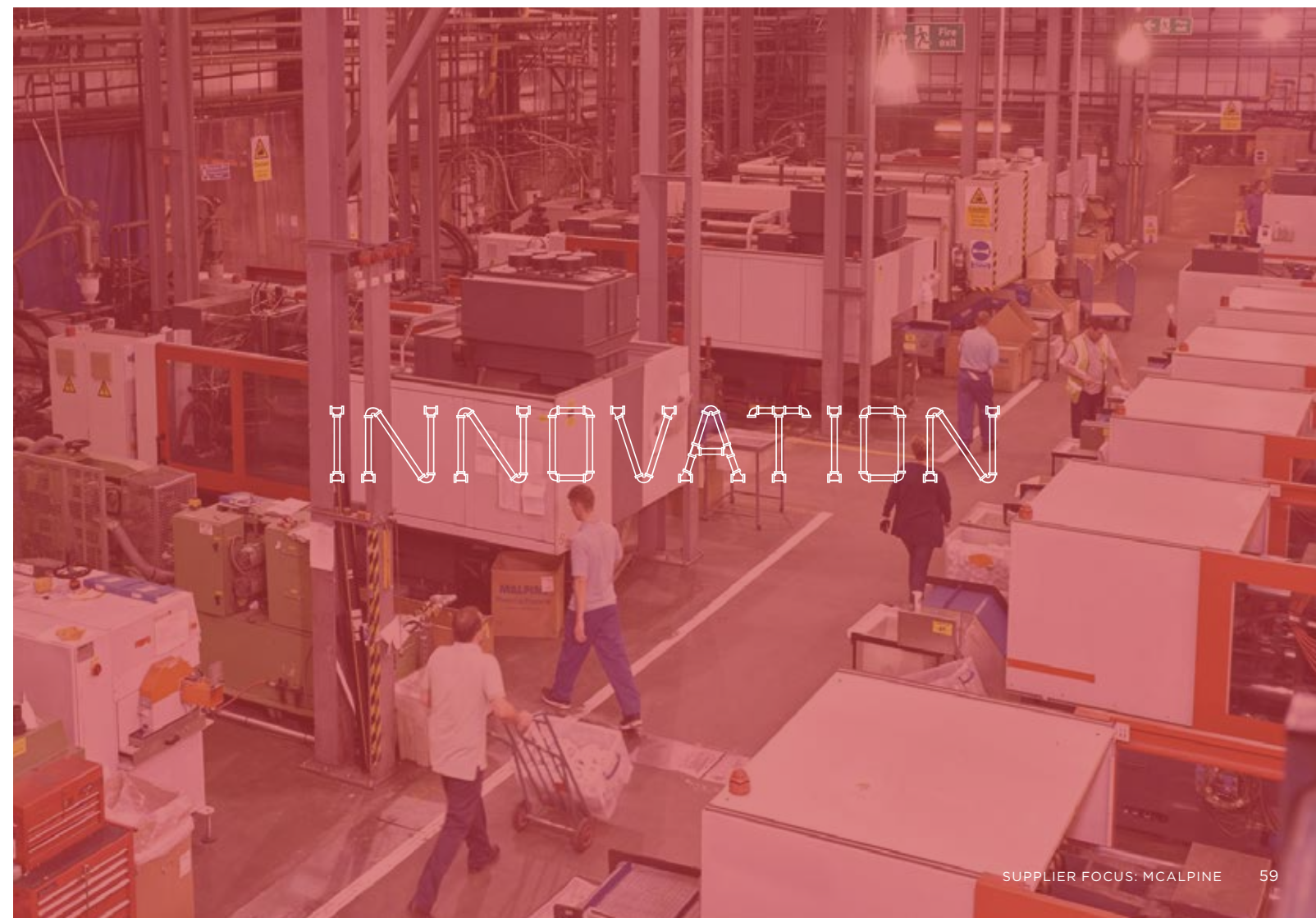

Q&A



Robert McAlpine,
Managing Director
mcalpineplumbing.com

Q. McAlpine is a family business. When and how was the company founded?

A. The company was initially founded in 1902, under the trading name of Egerton & Co., located in Govan, Glasgow. My Great Grand Father, J B McAlpine (founder), was the foreman in the factory before taking over the business. In 1906 he changed the company to the name McAlpine & Co Ltd.

Originally we manufactured lead pipes and traps. However, when my late father, J E McAlpine (who sadly passed away in 2021), joined the business in 1956/57, he insisted he would only join the company if we moved into the production of plastic.

My father was the third generation of McAlpine to work in the company. His insistence resulted in the company becoming the first producer of plastic plumbing products globally. Ironically the first trap produced is still on sale today and is still the market leader in the UK.

This event was vital in our history and began the story of pioneering at the core of McAlpine today.

Q. In what areas do you specialise?

A. At McAlpine, innovation is our key area of expertise. We are constantly investing in research and development, moving our product range and the world of plumbing forward.

Q. What do you think makes McAlpine unique?

A. Our trusted name. This trust has been built on over 100 years of

Innovation is our key area of expertise. We are constantly investing in research and development, moving our product range and the world of plumbing forward



innovation and is an acceptance that you can install our products easily and they work.

Q. Are there any new/interesting/innovative products coming out of McAlpine soon?

A. We are always looking to push our product range to the next level. This drive is why I enjoy working with innovative OEMs such as Carron Bathrooms, who think the same way.

This drive to innovate has led us to develop a new pipe fitting system called Suregrip, which will launch in 2022.

We are aiming to combine this products' unique function with existing products. And as a result, we have invested in new plant equipment to support the manufacturing and further expanded two of our factories in size.

Q. What areas of growth or change in the plumbing materials trade are you seeing now?

A. The pandemic has changed the way people interact with businesses, which is no different for the plumbing and bathroom trade. On the back of this, we have been making our product information more 'social' friendly with online videos to help explain our existing product range and to help launch new products.

McAlpine home orders have been a strong area of growth as well, helped by the fact that we are one of the few manufacturers who can continue production over the last two years. It hasn't been easy to achieve this under current circumstances, but we've

been able to make the most of these opportunities.

Q. How long have you worked with Carron Bathrooms?

A. The first time I worked directly with Carron Bathrooms was on the Celsius Range project back in 2008.

Carron Bathrooms had developed a new bath design with the sharpest edges I had seen on an acrylic, moulded bath with a unique overflow design that sat flush with the tub. During our meetings with Carron Bathrooms, the idea was born to add a waterfall to the overflow plate.

It was a really enjoyable and rewarding project co-developing this great idea with Carron Bathrooms. And the fact the Celsius Freestanding model is still selling well and looks fresh to this day is testimony to the Carron design process.

Q. Why would you recommend Carron Bathrooms / Carron products?

A. When you buy a Carron bath, you buy a product born from a company with a reputation for quality and innovation.

Carron Bathrooms are a family business, and they treat their customers like family, and when occasionally there is an issue, they work with the customer to achieve satisfaction. In industry, you are rarely praised for good work, so the nearest we can get to this is good feedback on how well we can deal with complaints.

They are proud of their baths and the service they provide.

Q. Finally, what tips would you give people when choosing a new bath?

A. Whatever company you work with, you need to know they will support you at the planning stage and if you hit any unforeseen issues during the installation phase of the project.

Your Carron bath should be a source of relaxation, not stress. And you are making a significant investment in your bathroom; it doesn't pay to save pennies at this stage.

The bath itself represents the crowning statement in the bathroom. However, aside from looking perfect, it must be functional. You want to know any problems will be taken care of should there be an issue.

Invest in both the installation and the products themselves, and your bathroom will continue to look good long after you have installed it.



Carronite™

They say still waters run deep and when you opt for the Carronite™ finish for your Carron bath, it's what you can't see that makes all the difference.

Carronite™ is Carron Bathrooms' unique, market leading finishing system which not only adds to your bathing experience but has a range of features that can benefit your pocket and the environment.

STRENGTH OF CARRONITE™



STRONGER

It's our unique process that creates the added strength found in all Carronite™ baths. A stronger bath is a more rigid bath, resulting in a more solid experience when bathing or showering.



WARMER FOR LONGER

Due to the extra finishing layers, Carronite™ baths are able to keep water temperature levels hotter for longer. Up to thirty minutes longer in some tests.



PEACE OF MIND

We are so confident in the quality and finish of our Carronite™ baths that we give every bath a 30 year guarantee. That's because Carronite™ baths are designed to last a lifetime.

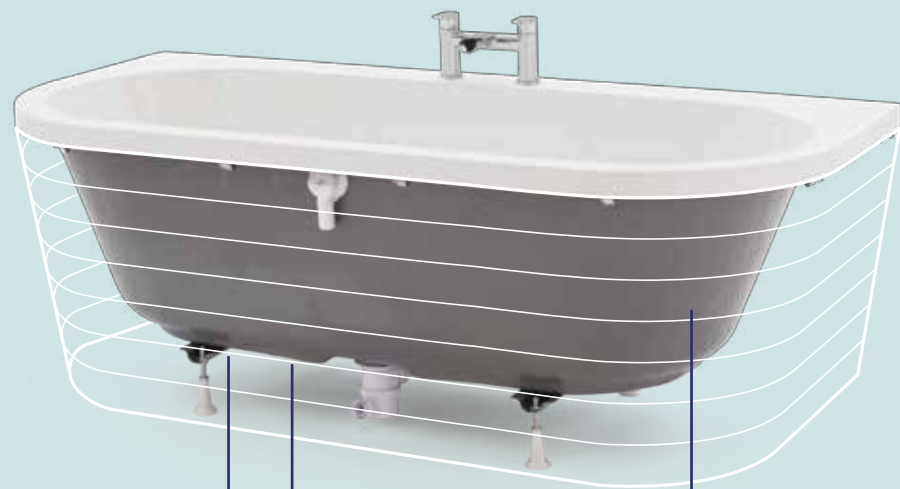

THE SUPPORT

Created specifically for the Carronite™ Baseboard, this unique frame, and foot set uses the added weight and thickness of our baths to deliver additional stability and security.

THE BASEBOARD

Custom baseboards, cut to size for each Carronite™ model, are applied by hand before the Carronite™ finish is applied.

THE FINISH

Specially formulated, our unique Carronite™ finish results in increased rigidity while the density of the material allows greater heat retaining properties.

CARRONITE™ FAQs

1



STRONGER

The increased strength delivered by the Carronite™ finish results in a stronger, more rigid bath. No more creaking when having a shower and a feeling of luxury and security when having a long soak.

2



BETTER FOR THE ENVIRONMENT

When a full bath keeps it's heat for longer there's less need to top it up with hot water. That's better for your gas bill and the environment.

3



PROFESSIONAL CHOICE

Plumbers and fitters need a job to go smoothly and the last thing they need is to return to a customer because of problems. Carronite™ baths are the choice of the professional because their consistent quality is something that professionals can rely on.

4

WARMER FOR LONGER

Due to the extra finishing layers, Carronite™ baths are able to keep water temperature levels hotter for longer. Up to thirty minutes longer in some tests.

5



30 YEAR GUARANTEE

What speaks volumes about the benefits of the product is Carron's willingness to back their unique process with a 30 year guarantee on all Carronite™ baths.



Product Range

What makes the Carron Bathrooms Product Range unique is the vast range of bath options available. Every one built then finished by hand to reach our highest levels of quality and conformity.

And we constantly listen to our customers in the trade. This way we can continue to expand our range to not only feature new bath designs and concepts, but also size options for each range.

Every bathroom fit-out is unique and we aim to ensure there is the right bath for every customers' needs.

Rectangular Baths



Alpha

LENGTH X WIDTH	HEIGHT	DEPTH	CAPACITY
1700 x 700mm	515mm	400mm	160 Litres
1700 x 750mm	540mm	425mm	175 Litres
1800 x 800mm	540mm	440mm	220 Litres



Apex

FEATURES:

LENGTH X WIDTH	HEIGHT	DEPTH	CAPACITY
1700 x 800mm	540mm	430mm	210 Litres



Arc

FEATURES:

LENGTH X WIDTH	HEIGHT	DEPTH	CAPACITY
1500 x 700mm	515mm	400mm	150 Litres
1700 x 700mm	515mm	400mm	172 Litres
1700 x 750mm	540mm	420mm	195 Litres



Arc Duo

LENGTH X WIDTH	HEIGHT	DEPTH	CAPACITY
1700 x 750mm	540mm	420mm	190 Litres
1800 x 800mm	540mm	430mm	210 Litres



Axis

FEATURES:

LENGTH X WIDTH	HEIGHT	DEPTH	CAPACITY
1500 x 700mm	430mm	345mm	131 Litres
1600 x 700mm	430mm	345mm	138 Litres
1650 x 700mm	430mm	345mm	142 Litres
1700 x 700mm	430mm	345mm	145 Litres



Britannia

FEATURES:

LENGTH X WIDTH	HEIGHT	DEPTH	CAPACITY
1700 x 700mm	515mm	370mm	155 Litres
1700 x 750mm	540mm	460mm	210 Litres
1800 x 800mm	540mm	430mm	245 Litres



Camden

FEATURES:

LENGTH X WIDTH	HEIGHT	DEPTH	CAPACITY
1600 x 700mm	515mm	405mm	192 Litres
1650 x 700mm	515mm	400mm	200 Litres
1700 x 700mm	515mm	405mm	209 Litres



Delta

FEATURES:

LENGTH X WIDTH	HEIGHT	DEPTH	CAPACITY
1400 x 700mm	515mm	410mm	142 Litres
1500 x 700mm	515mm	410mm	152 Litres
1600 x 700mm	515mm	410mm	162 Litres
1650 x 700mm	515mm	410mm	167 Litres
1675 x 700mm	515mm	410mm	170 Litres
1700 x 700mm	515mm	410mm	170 Litres



Echelon (inc filler)

LENGTH X WIDTH	HEIGHT	DEPTH	CAPACITY
1700 x 750mm	540mm	420mm	209 Litres
1800 x 800mm	540mm	440mm	230 Litres



Equation

LENGTH X WIDTH	HEIGHT	DEPTH	CAPACITY
1700 x 750mm	540mm	420mm	205 Litres
1800 x 800mm	540mm	430mm	233 Litres



Equity

LENGTH X WIDTH	HEIGHT	DEPTH	CAPACITY
1700 x 750mm	540mm	420mm	204 Litres
1800 x 800mm	540mm	440mm	225 Litres



Haiku

LENGTH X WIDTH	HEIGHT	DEPTH	CAPACITY
1700 x 800mm	540mm	450mm	220 Litres
1800 x 800mm	540mm	450mm	230 Litres
1800 x 900mm	540mm	450mm	290 Litres



Highgate Duo

FEATURES:

LENGTH X WIDTH	HEIGHT	DEPTH	CAPACITY
1700 x 750mm	540mm	430mm	210 Litres
1800 x 800mm	540mm	430mm	264 Litres



Highgate SE

FEATURES:

LENGTH X WIDTH	HEIGHT	DEPTH	CAPACITY
1700 x 750mm	540mm	420mm	216 Litres
1800 x 800mm	540mm	430mm	268 Litres



Index

FEATURES:

LENGTH X WIDTH	HEIGHT	DEPTH	CAPACITY
1700 x 750mm	540mm	430mm	195 Litres



Imperial TG

FEATURES:

LENGTH X WIDTH	HEIGHT	DEPTH	CAPACITY
1400 x 700mm	515mm	400mm	135 Litres
1500 x 700mm	515mm	400mm	145 Litres
1600 x 700mm	515mm	400mm	162 Litres
1675 x 700mm	515mm	400mm	180 Litres
1700 x 700mm	515mm	400mm	180 Litres
1800 x 750mm	540mm	420mm	210 Litres

Rectangular Baths



Linea

LENGTH X WIDTH	HEIGHT	DEPTH	CAPACITY
1900 x 900mm	570mm	460mm	345 Litres



Mistral

LENGTH X WIDTH	HEIGHT	DEPTH	CAPACITY
1800 x 700-900mm	570mm	480mm	330 Litres



Matrix

FEATURES:

LENGTH X WIDTH	HEIGHT	DEPTH	CAPACITY
1500 x 700mm	515mm	345mm	131 Litres
1600 x 700mm	515mm	345mm	138 Litres
1650 x 700mm	515mm	345mm	142 Litres
1700 x 700mm	515mm	345mm	145 Litres



Profile

FEATURES:

LENGTH X WIDTH	HEIGHT	DEPTH	CAPACITY
1500 x 700mm	515mm	400mm	190 Litres
1600 x 700mm	515mm	400mm	204 Litres
1700 x 700mm	515mm	400mm	218 Litres
1700 x 750mm	540mm	430mm	257 Litres
1750 x 750mm	540mm	410mm	264 Litres
1800 x 700mm	540mm	400mm	255 Litres



Profile Duo

FEATURES:

LENGTH X WIDTH	HEIGHT	DEPTH	CAPACITY
1600 x 700mm	515mm	410mm	188 Litres
1600 x 800mm	540mm	410mm	215 Litres
1650 x 700mm	515mm	410mm	196 Litres
1700 x 700mm	515mm	410mm	205 Litres
1700 x 750mm	540mm	410mm	230 Litres
1750 x 750mm	540mm	410mm	236 Litres
1800 x 700mm	540mm	410mm	231 Litres



Quantum Duo

FEATURES:

LENGTH X WIDTH	HEIGHT	DEPTH	CAPACITY
1700 x 700mm	515mm	410mm	165 Litres
1700 x 750mm	540mm	430mm	190 Litres
1700 x 800mm	540mm	440mm	200 Litres
1800 x 800mm	540mm	440mm	230 Litres
1900 x 900mm	570mm	450mm	350 Litres



Quantum Integra

FEATURES:

LENGTH X WIDTH	HEIGHT	DEPTH	CAPACITY
1500 x 700mm	515mm	410mm	198 Litres
1600 x 700mm	515mm	410mm	213 Litres
1650 x 700mm	515mm	410mm	216 Litres
1700 x 700mm	515mm	410mm	228 Litres
1700 x 750mm	540mm	430mm	240 Litres
1700 x 800mm	540mm	440mm	267 Litres
1750 x 750mm	540mm	430mm	247 Litres
1800 x 800mm	540mm	440mm	285 Litres



Quantum Integra Eco

FEATURES:

LENGTH X WIDTH	HEIGHT	DEPTH	CAPACITY
1500 x 700mm	430mm	345mm	152 Litres
1500 x 700mm	515mm	345mm	152 Litres
1600 x 700mm	430mm	345mm	165 Litres
1600 x 700mm	515mm	345mm	165 Litres
1700 x 700mm	430mm	345mm	174 Litres
1700 x 700mm	515mm	345mm	174 Litres



Quantum Spacesaver

FEATURES:

LENGTH X WIDTH	HEIGHT	DEPTH	CAPACITY
1700 x 400-750mm	540mm	420mm	211 Litres

Available in right hand or left hand. Right hand shown.



Quantum SE

FEATURES:

LENGTH X WIDTH	HEIGHT	DEPTH	CAPACITY
1500 x 700mm	515mm	410mm	198 Litres
1600 x 700mm	515mm	410mm	213 Litres
1600 x 800mm	540mm	430mm	247 Litres
1700 x 700mm	515mm	410mm	228 Litres
1700 x 750mm	540mm	430mm	240 Litres
1700 x 800mm	540mm	440mm	267 Litres

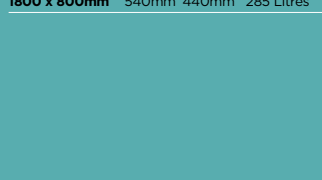

Status

FEATURES:

LENGTH X WIDTH	HEIGHT	DEPTH	CAPACITY
1600 x 725mm	540mm	425mm	197 Litres
1700 x 725mm	540mm	425mm	205 Litres
1700 x 800mm	540mm	450mm	250 Litres

Available in right hand or left hand. Right hand shown.



Sigma

FEATURES:

LENGTH X WIDTH	HEIGHT	DEPTH	CAPACITY
1600 x 750mm	540mm	420mm	175 Litres
1700 x 750mm	540mm	440mm	195 Litres
1700 x 800mm	540mm	450mm	220 Litres
1800 x 800mm	540mm	450mm	240 Litres
1900 x 900mm	570mm	460mm	350 Litres



Swallow TG

FEATURES:

LENGTH X WIDTH	HEIGHT	DEPTH	CAPACITY
1700 x 700mm	515mm	370mm	182 Litres
1800 x 700mm	540mm	365mm	185 Litres



Urban

FEATURES:

LENGTH X WIDTH	HEIGHT	DEPTH	CAPACITY
1700 x 725mm	540mm	410mm	224 Litres



Urban Sitbath

LENGTH X WIDTH	HEIGHT	DEPTH	CAPACITY
1250 x 725mm	540mm	450mm	155 Litres

Depth at deepest point.

Showerbaths



Arc

FEATURES:

LENGTH X WIDTH	HEIGHT	DEPTH	CAPACITY
1700 x 700-850mm	540mm	430mm	250 Litres

Available in right hand or left hand. Left hand shown.



Aspect

FEATURES:

LENGTH X WIDTH	HEIGHT	DEPTH	CAPACITY
1700 x 700-800mm	430mm	345mm	190 Litres

Available in right hand or left hand. Left hand shown.



Delta

FEATURES:

LENGTH X WIDTH	HEIGHT	DEPTH	CAPACITY
1600 x 700-800mm	540mm	410mm	210 Litres
1700 x 700-800mm	540mm	420mm	230 Litres

Available in right hand or left hand. Left hand shown.



Highgate Showerbath

FEATURES:

LENGTH X WIDTH	HEIGHT	DEPTH	CAPACITY
1700 x 750-900mm	540mm	430mm	272 Litres

Available in right hand or left hand. Left hand shown.



Profile Showerbath

FEATURES:

LENGTH X WIDTH	HEIGHT	DEPTH	CAPACITY
1500 x 900mm	540mm	440mm	241 Litres

Available in right hand or left hand. Left hand shown. Not suitable to be recessed.



Quantum

FEATURES:

LENGTH X WIDTH	HEIGHT	DEPTH	CAPACITY
1500 x 700-850mm	540mm	420mm	229 Litres
1600 x 700-850mm	540mm	420mm	250 Litres
1700 x 700-850mm	540mm	420mm	265 Litres

Available in right hand or left hand. Left hand shown.



Status Showerbath

FEATURES:

LENGTH X WIDTH	HEIGHT	DEPTH	CAPACITY
1550 x 850mm	540mm	450mm	262 Litres

Available in right hand or left hand. Right hand shown.



Sigma

FEATURES:

LENGTH X WIDTH	HEIGHT	DEPTH	CAPACITY
1800 x 750-900mm	540mm	450mm	265 Litres

Available in right hand or left hand. Left hand shown.



Urban Compact

FEATURES:

LENGTH X WIDTH	HEIGHT	DEPTH	CAPACITY
1500 x 750-900mm	540mm	420mm	228 Litres

Available in right hand or left hand. Left hand shown.



Urban

FEATURES:

LENGTH X WIDTH	HEIGHT	DEPTH	CAPACITY
1700 x 750-900mm	540mm	420mm	260 Litres

Available in right hand or left hand. Left hand shown.



Urban edge

FEATURES:

LENGTH X WIDTH	HEIGHT	DEPTH	CAPACITY
1575 x 700-850mm	540mm	420mm	225 Litres
1675 x 700-850mm	540mm	420mm	245 Litres

Available in right hand or left hand. Left hand shown.



Urban swing

FEATURES:

LENGTH X WIDTH	HEIGHT	DEPTH	CAPACITY
1575 x 850mm	540mm	420mm	225 Litres

Available in right hand or left hand. Left hand shown.

Freestanding Baths



Ascoli

LENGTH X WIDTH HEIGHT DEPTH CAPACITY
1700 x 750mm 650mm 480mm 247 Litres

Inset option available.



Celsius

LENGTH X WIDTH HEIGHT DEPTH CAPACITY
1910 x 910mm 610mm 450mm 330 Litres

Includes Filler.



Elysee

LENGTH X WIDTH HEIGHT DEPTH CAPACITY
1800 x 900mm 650mm 480mm 330 Litres

Inset option available.



Halcyon D

LENGTH X WIDTH HEIGHT DEPTH CAPACITY
1750 x 800mm 540mm 450mm 253 Litres

Features: Back to Wall, Detachable Panel



Halcyon Oval

LENGTH X WIDTH HEIGHT DEPTH CAPACITY
1750 x 800mm 610mm 450mm 270 Litres

Inset option available.



Halcyon Square

LENGTH X WIDTH HEIGHT DEPTH CAPACITY
1750 x 800mm 600mm 440mm 286 Litres

Inset option available.

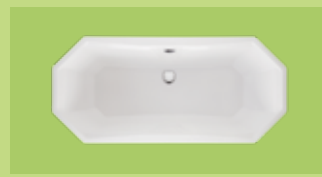

Highgate Freestanding

LENGTH X WIDTH HEIGHT DEPTH CAPACITY
1750 x 800mm 620mm 440mm 265 Litres



Paradigm

LENGTH X WIDTH HEIGHT DEPTH CAPACITY
1550 x 850mm 620-660mm 480mm 238 Litres

Bath Features Key

Baths arranged alphabetically by family. All dimensions shown are in millimetres and capacity in litres.

- Suitable for Showering
- Handgrip option available
- Water saver
- Ease of access

Grip Options

Chrome handgrips available on rectangular baths with the Handgrip Icon . Please order using appropriate product code.



CCG-1 Chrome Handgrip
Delta, Sigma



CCG-2 Chrome Handgrip
Axis, Matrix, Index, Apex, Arc



CCG-3 Anthracite Integra Handgrip
Quantum Integra only

Corner Baths

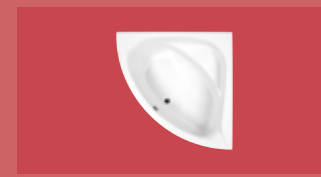

Centennial

LENGTH X WIDTH HEIGHT DEPTH CAPACITY
1500 x 1500mm 570mm 495mm 407 Litres



Dove

LENGTH X WIDTH HEIGHT DEPTH CAPACITY
1550 x 950mm 540mm 400mm 190 Litres

Available in right hand or left hand. Left hand shown.

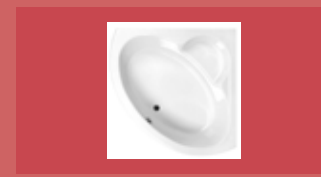

Monarch

LENGTH X WIDTH HEIGHT DEPTH CAPACITY
1300 x 1300mm 540mm 400mm 235 Litres



Omega

LENGTH X WIDTH HEIGHT DEPTH CAPACITY
1700 x 1000mm 540mm 445mm 255 Litres

Available in right hand or left hand. Left hand shown.

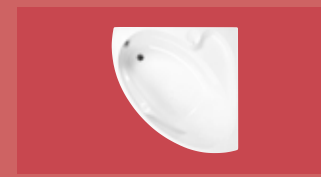

Oriole

LENGTH X WIDTH HEIGHT DEPTH CAPACITY
1200 x 1200mm 540mm 400mm 190 Litres

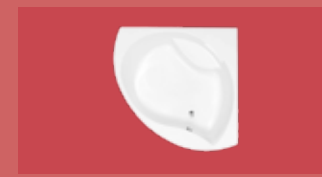

Tranquility

LENGTH X WIDTH HEIGHT DEPTH CAPACITY
1300 x 1300mm 540mm 450mm 295 Litres



Clipper

LENGTH X WIDTH HEIGHT DEPTH CAPACITY
1200 x 1575mm 580mm 475mm 335 Litres

Available in right hand or left hand. Left hand shown.

Celsius Range



Celsius

FEATURES:

LENGTH X WIDTH HEIGHT DEPTH CAPACITY
1700 x 700mm 540mm 430mm 265 Litres
1700 x 750mm 540mm 450mm 275 Litres

Available in right hand or left hand. Right hand shown.



Celsius 1800

LENGTH X WIDTH HEIGHT DEPTH CAPACITY
1800 x 800mm 540mm 450mm 300 Litres



Celsius Duo

LENGTH X WIDTH HEIGHT DEPTH CAPACITY
2000 x 1400mm 570mm 480mm 560 Litres



Celsius Oval

LENGTH X WIDTH HEIGHT DEPTH CAPACITY
1900 x 1000mm 570mm 470mm 320 Litres



Celsius Showerbath

FEATURES:

LENGTH X WIDTH HEIGHT DEPTH CAPACITY
1700 x 750-900mm 540mm 450mm 305 Litres

Available in right hand or left hand. Left hand shown.

PRODUCT FOCUS:

HIGHLAND SOAP HIGHLAND LAVENDER

Organic Aloe Vera Hand Wash

300ML

Naturally anti-bacterial organic Lavender Hand Wash with aloe vera to help soothe and cleanse hard working hands. Refreshing and moisturising, this hand wash is naturally fragranced with plant extracts and essential oils.



Hand & Body Organic Cream

120ML

Made with pure Lavender essential oil and naturally scented. This organic cream has antiseptic and healing properties, and is known to be soothing to skin.



Organic Handmade Soap

150g

This moisturising soap is made with skin-loving glycerine from certified organic vegetable oils. Naturally fragranced with plant extracts and essential oils.



Organic Aloe Vera Bubble Bath

500ML

Immerse yourself in a warm sanctuary of botanically charged creamy bubbles scented with pure lavender essential oil. Pour into a warm bath, lie back and relax. Enriched with soothing aloe vera, nettle, lavender and chamomile natural plant extracts.



Hand & Body Organic Lotion

300ML

A nourishing hand and body lotion scented with pure lavender essential oil. Elegant and light, our moisturising lotions blend shea and cocoa butters, olive oil, aloe vera and extracts of lavender, chamomile and nettle.



This range of organic products help bring a new level of relaxation.

The Highland Soap Company is a small, family-owned business that makes organic soap and skincare products at our workshop in Fort William-nestled next to the River Lochy, overlooking Ben Nevis.

The Highland Lavender range covers organic soaps and skincare products to candles and diffusers. All the products are made using highland lavender essential oil, which has the light, soft aroma of fresh flowers. As well as its wonderful scent, the lavender oil promotes relaxation and aids sleep.

Available online at highlandsoaps.com



Bold statements, experimental finishes and ground breaking interiors. Enter the world of contemporary bathroom design with Carron Bathrooms.



THE NAME
FOR BATHS

PROUD MEMBER OF:

